

PERFORMANCE SERIES EXHAUST BELLOWS

Auto-jet₊
MUFFLER CORP.

Designed to meet the unique challenges of the most demanding applications, Auto-jet Performance Series Exhaust Bellows are engineered to outperform at the highest levels and take the typical guesswork out of your bellows selection.

1

ZERO SCRAP WELD CAP

- T304 SS Construction
- Delivers Superior Weld Surface Presentation
- Reduces Risk of Weld-Related Failures
- Offers Ease of Assembly | Sealing
- Increases Tangent | Exterior Braid Support
- Adds Bellows Protection from Weld Spatter

2

INDUSTRY-LEADING BELLOWS DESIGN

- Multi-ply T321 SS Construction
- Proven | Proprietary Convolution Geometry
- Hydroformed for Consistency | Predictability
- Designed to Exceed Standard Life Cycles
- Resists Fatigue | Vibration
- Most Sizes in Stock

3

MULTI-DIRECTIONAL WIRE BRAIDED COVER

- T304 SS Construction
- Adds Vibration Resistance
- Increases Thermal Insulation
- Tolerates Multi-directional Movement
- Restrains Non-specified Motions
- Protects Bellows from:
 - Debris
 - Installation Damage
 - Corrosive Elements

4

SEGMENTED INTERLOCK LINER

- T304 SS Construction
- Ultimate Durability | Flexibility
- Eliminates Flow-Induced Noise | Vibration
- Supports Multi-directional Movement
- Increases Thermal Insulation
- Exceptional Flow Characteristics

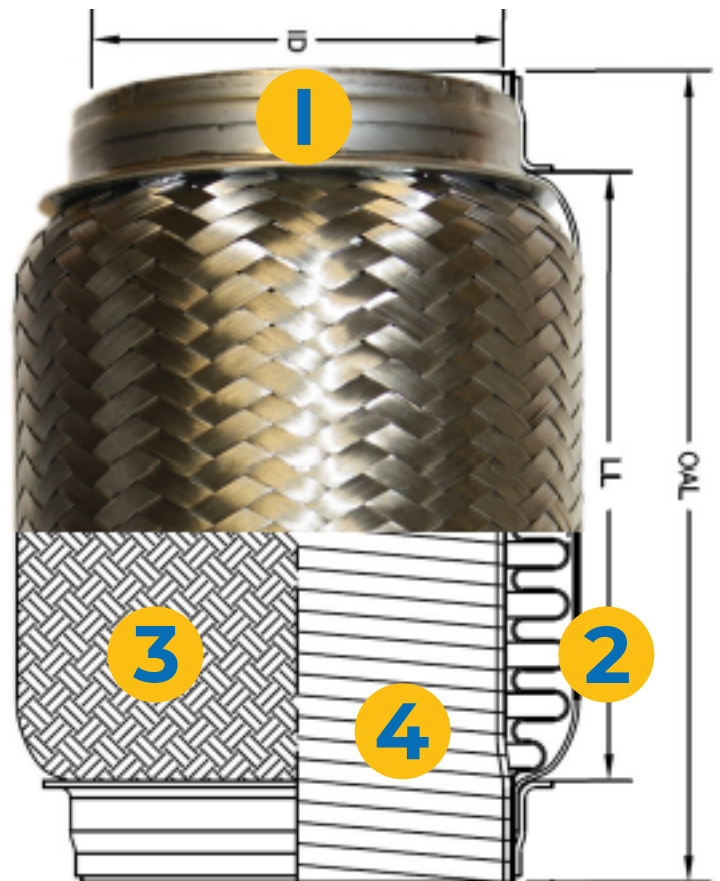

CONTACT US TODAY!

sales@auto-jet.com

800-247-5391

www.auto-jet.com

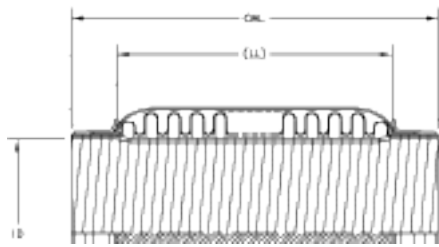

800-247-5391
sales@auto-jet.com
www.auto-jet.com

TUBE SIZE Nominal ID*	LENGTHS in.		MOVEMENT in.		SPRING RATES #/in.	
	LIVE	OVERALL	AXIAL	LATERAL	AXIAL	LATERAL
1.75	2.5	4	0.4	0.1	88	107
1.75	4.5	6	0.7	0.25	49	19
1.75	6.5	8	1	0.35	34	6
2	2.5	4	0.4	0.1	92	142
2	3.5	5	0.5	0.2	65	52
2	4.5	6	0.7	0.25	51	25
2	6.5	8	1.1	0.35	35	8
2.25	2.5	4	0.4	0.1	101	188
2.25	3.5	5	0.5	0.2	72	68
2.25	4.5	6	0.7	0.25	56	33
2.25	6.5	8	1.1	0.35	39	11
2.5	2.5	4	0.4	0.1	108	244
2.5	3.5	5	0.5	0.2	74	85
2.5	4.5	6	0.7	0.25	57	39
2.5	6.5	8	1.1	0.35	38	13
3	2.5	4	0.4	0.1	105	352
3	3.5	5	0.5	0.2	69	110
3	4.5	6	0.7	0.25	59	63
3	5.5	7	0.9	0.3	52	33
3	6.5	8	1.1	0.35	41	21
3	8.5	10	1.4	0.5	61	18
3	10.5	12	1.7	0.6	56	11
3.5	2.5	4	0.4	0.1	110	489
3.5	4.5	6	0.7	0.25	62	87
3.5	6.5	8	1.1	0.35	43	28
3.5	8.5	10	1.4	0.5	66	22
3.5	10.5	12	1.7	0.6	61	16
4	2.5	4	0.35	0.1	226	986
4	3.5	5	0.4	0.15	197	483
4	4.5	6	0.5	0.2	145	240
4	5.5	7	0.75	0.25	127	126
4	6.5	8	1	0.3	102	84
4	8.5	10	1.2	0.4	131	63
4	10.5	12	1.6	0.5	106	35
5	2.3	4	0.35	0.06	341	3477
5	4.3	6	0.5	0.15	193	539
5	6.3	8	1	0.3	220	300
5	8.3	10	1.2	0.4	176	136
5	10.3	12	1.6	0.5	147	74
6	2.3	4	0.3	0.06	513	7257
6	4.3	6	0.5	0.15	285	1146
6	6.3	8	0.75	0.2	450	843
6	8.3	10	1.1	0.25	310	339
6	10.3	12	1.5	0.35	266	191

* Bellows ID will fit over nominal TUBE size OD.