

2

1

40060E4.5X304 XX/XX

TUBE DIAMETER
 BEND ANGLE
 E
 BEND CLR
 X
 MATERIAL
 SPACE
 OPTIONAL SUFFIX FOR END FINISHING

END FINISHING OPTIONS

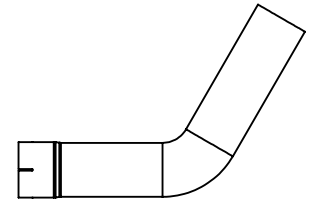
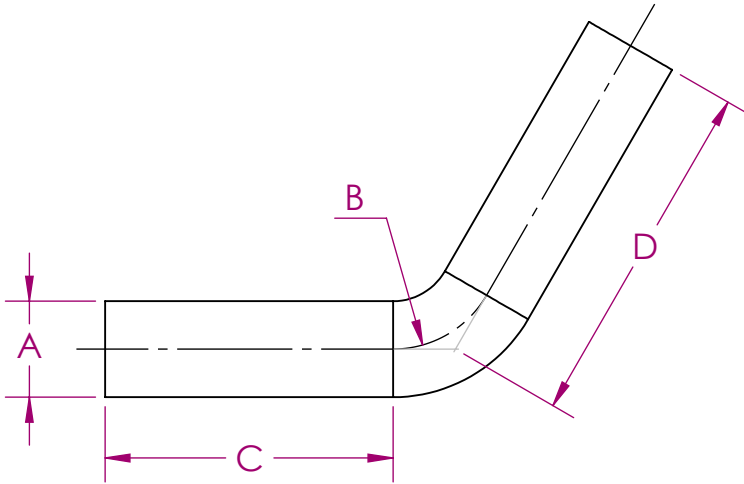

ID/OD

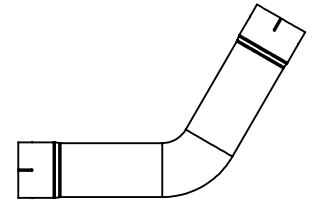

ID/ID

A	B	C	D	ALZ - 16GA	ALZ - 14GA	304SS	316SS	409SS
3	3.5	12	14	30060E3.5XAL		30060E3.5X304		
3.5	4	12	14.4	35060E4XAL		35060E4X304		
4	4.5	12	14.6	40060E4.5XAL		40060E4.5X304		
5	6	12	15.5	50060E6XAL		50060E6X304		
6	6	14	17.5	60060E6XAL		60060E6X304		

B

B

A

A

2

1